

MotorGuide® REPAIR PARTS

Tracker

BX30 BX40

PARTS ORDERING & TECH ASSISTANCE

MotorGuide Consumer Relations
Phone 918-831-6989
Fax 800-982-8093

Returned Goods must be accompanied with a Returned Goods Authorization. Contact MotorGuide Consumer Relations to obtain RGA.

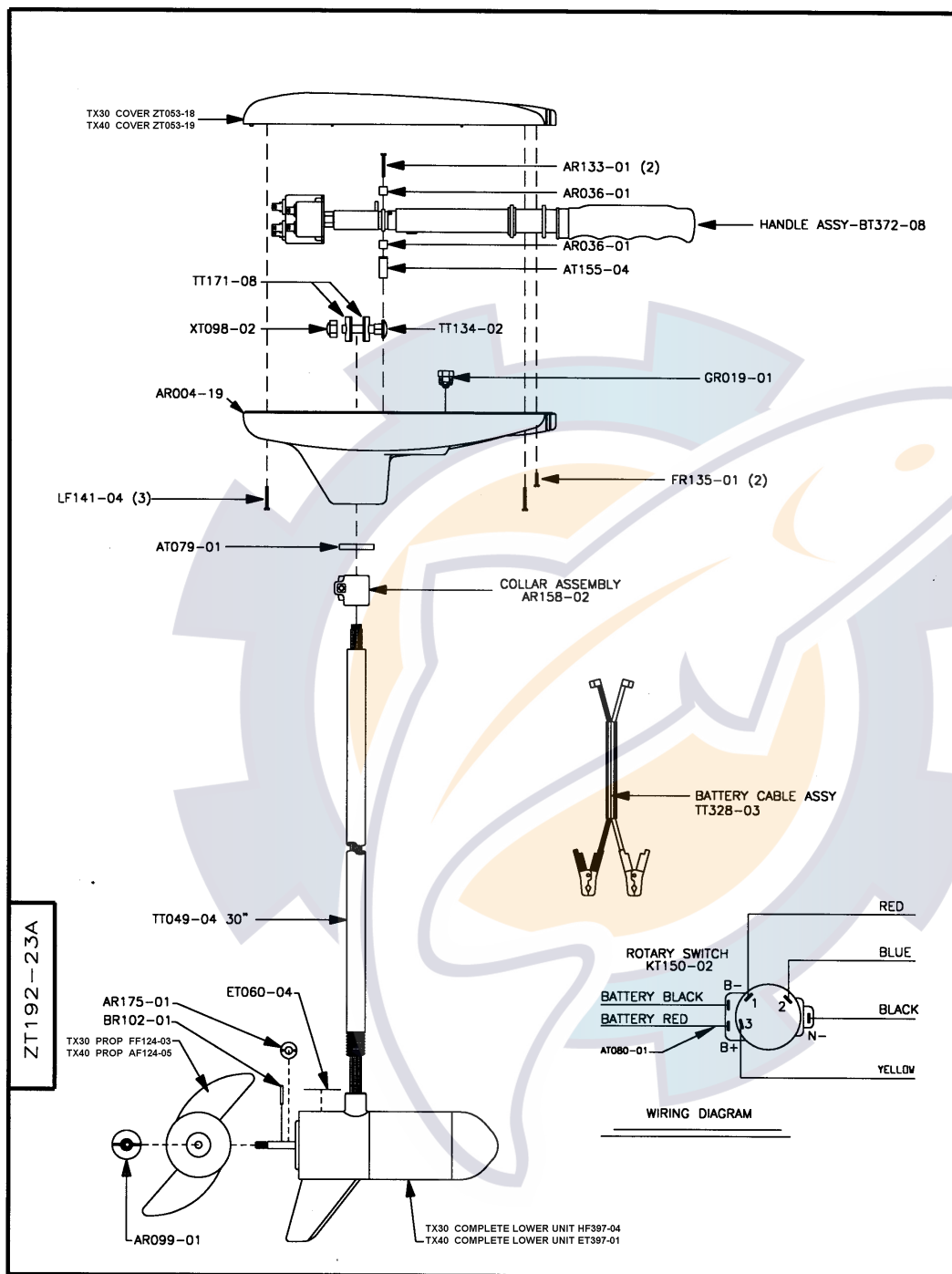

Tracker BX30

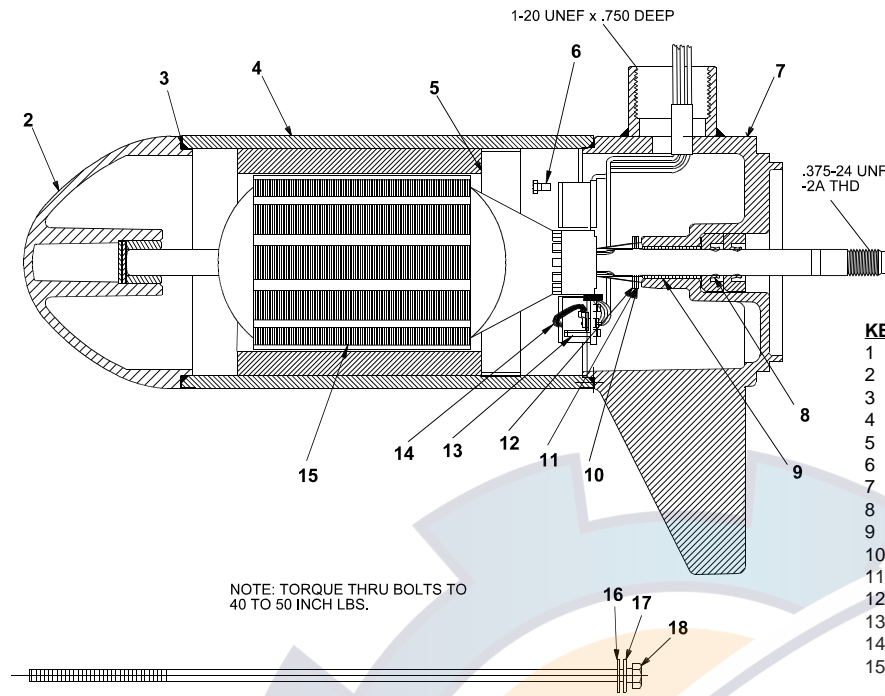

KEY	QTY	DESCRIPTION	PART NO.
1	X	MOTOR	HF397-04
2	1	NOSE CAP	FF3212-01
3	1	HOUSING ASY	HF3210-01
4	1	ARMATURE 3"	HF3207-02
5	1	BRUSH ASY LESS SPRING	FF3201-01
6	1	E RING	MR219-02
7	1	COMM CAP	FF3205-01
8	2	SHAFT SEAL	MR223-01
9	1	NYLATRON WASHER	MR226-01
10	1	WASHER	MR227-01
11	2	BRUSH SPRINGS	MR214-02
12	2	O RING SEAL	HF217-01
13	4	STATIC SEAL	MR222-01
14	4	THRU BOLT WASHER	MR216-01
15	2	THRU BOLT	MR218-00

Tracker BX40

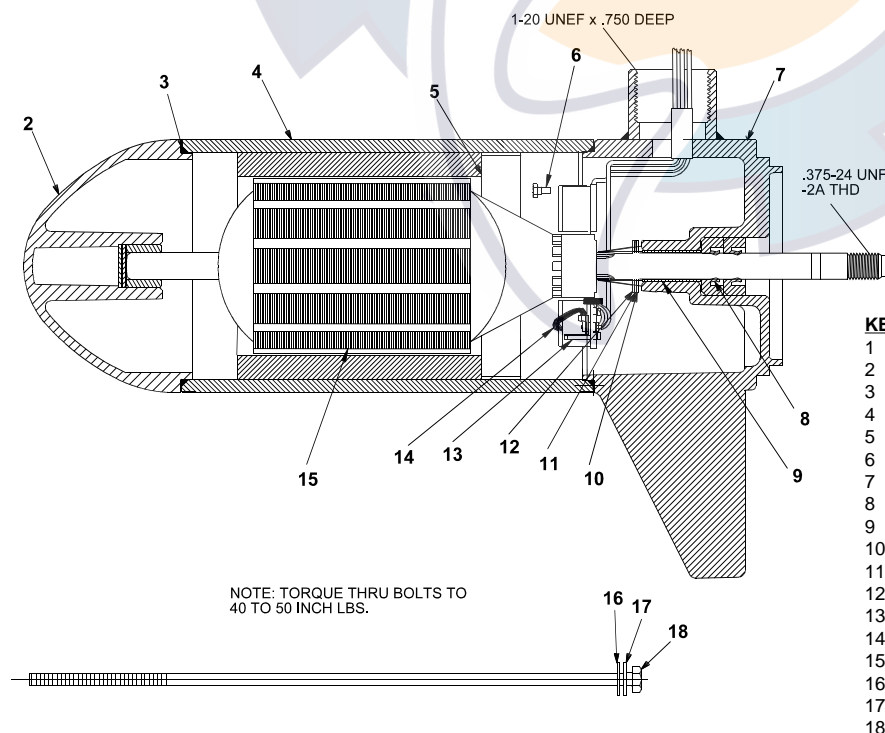

KEY	QTY	DESCRIPTION	PART NO.
1	X	MOTOR	ET397-01
2	1	NOSE CAP	JF3212-01
3	2	O RING SEAL	MR217-01
4	1	HOUSING ASY	ET3210-01
5	1	RETAINER	JF233-01
6	2	BRUSH CARD SCREW	MR228-01
7	1	COMM CAP	ET3205-01
8	2	SHAFT SEAL	MR223-01
9	1	BEARING	MR206-01
10	1	NYLATRON WASHER	MR226-01
11	1	WASHER	MR227-01
12	1	E RING	MR219-01
13	2	BRUSH SPRINGS	MR214-02
14	1	BRUSH ASY LESS SPRING	DF3201-01
15	1	ARMATURE	KF3207-01
16	4	STATIC SEAL	MR222-01
17	4	THRU BOLT WASHER	MR216-01
18	2	THRU BOLT	MR218-01